

Super Mini 3D Printer

Instruction

Tel:0086-574-88037579

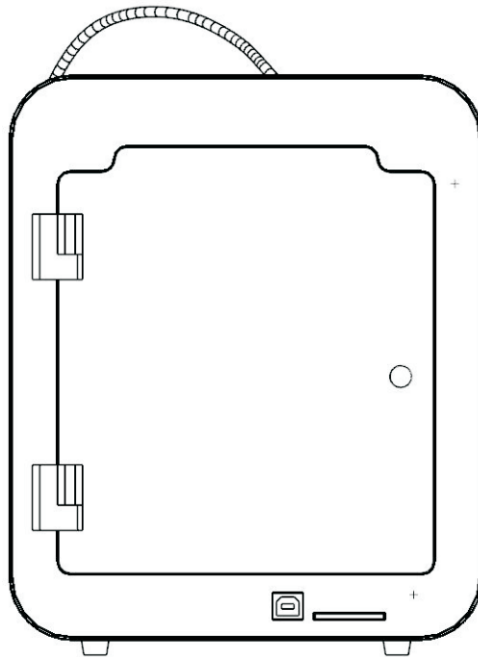

Scanning for more online Support

Super Mini Packing List

The items listed below are all the accessories in the box. Please check the items before using

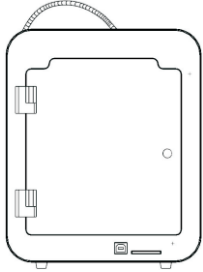

Super Mini 3D Printerx1

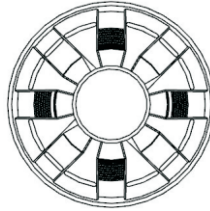

PLA Filament 1kgx1



Power Supply x1
USB Cablesx1

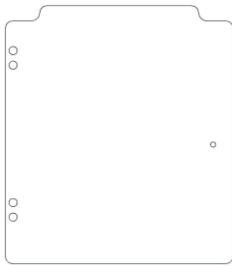

Door Plate x3

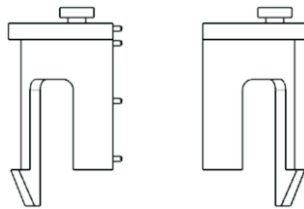

Filament Support x1

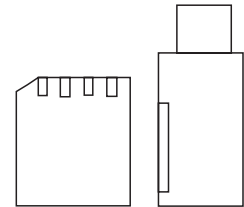

SD Cardx1 Card
Readerx1



Printing platform
(115x100mm)x1



Soft magnet palte
(105x105mm) x1

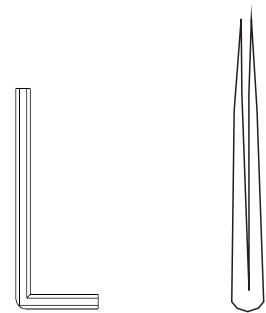

Wrenchx3
(1.5/2/2.5) Tweezersx1

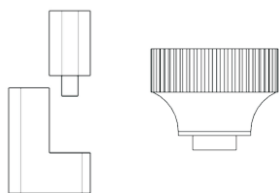

Plastic Partsx2
Thumb screw(M3X6)x8

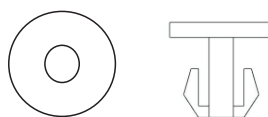

Circular magnets(12*6*1)x1
Bucklex8

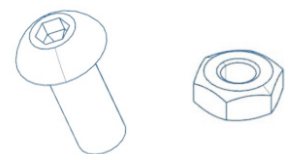

Screw (M4x6)x10

Appearance Introduction

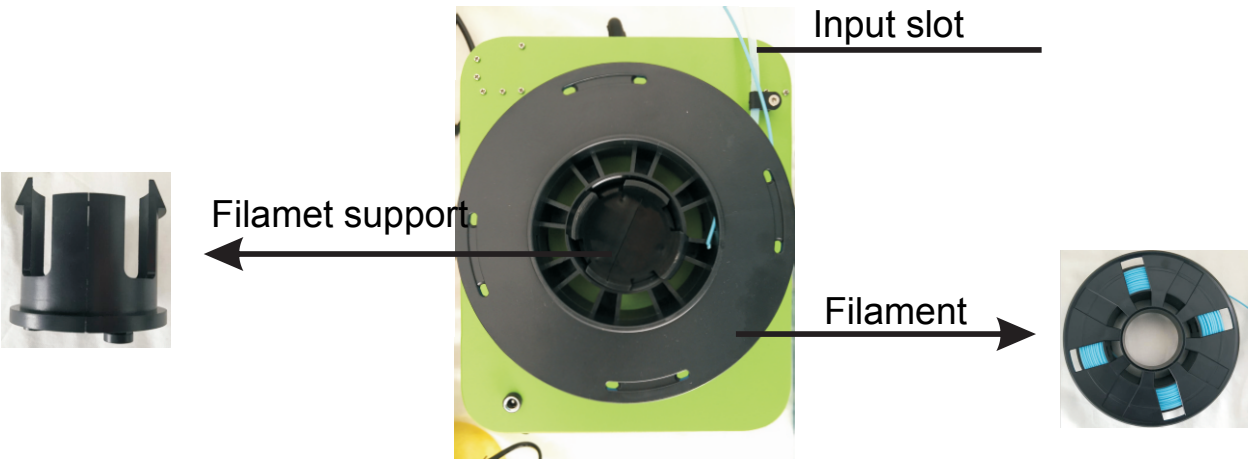
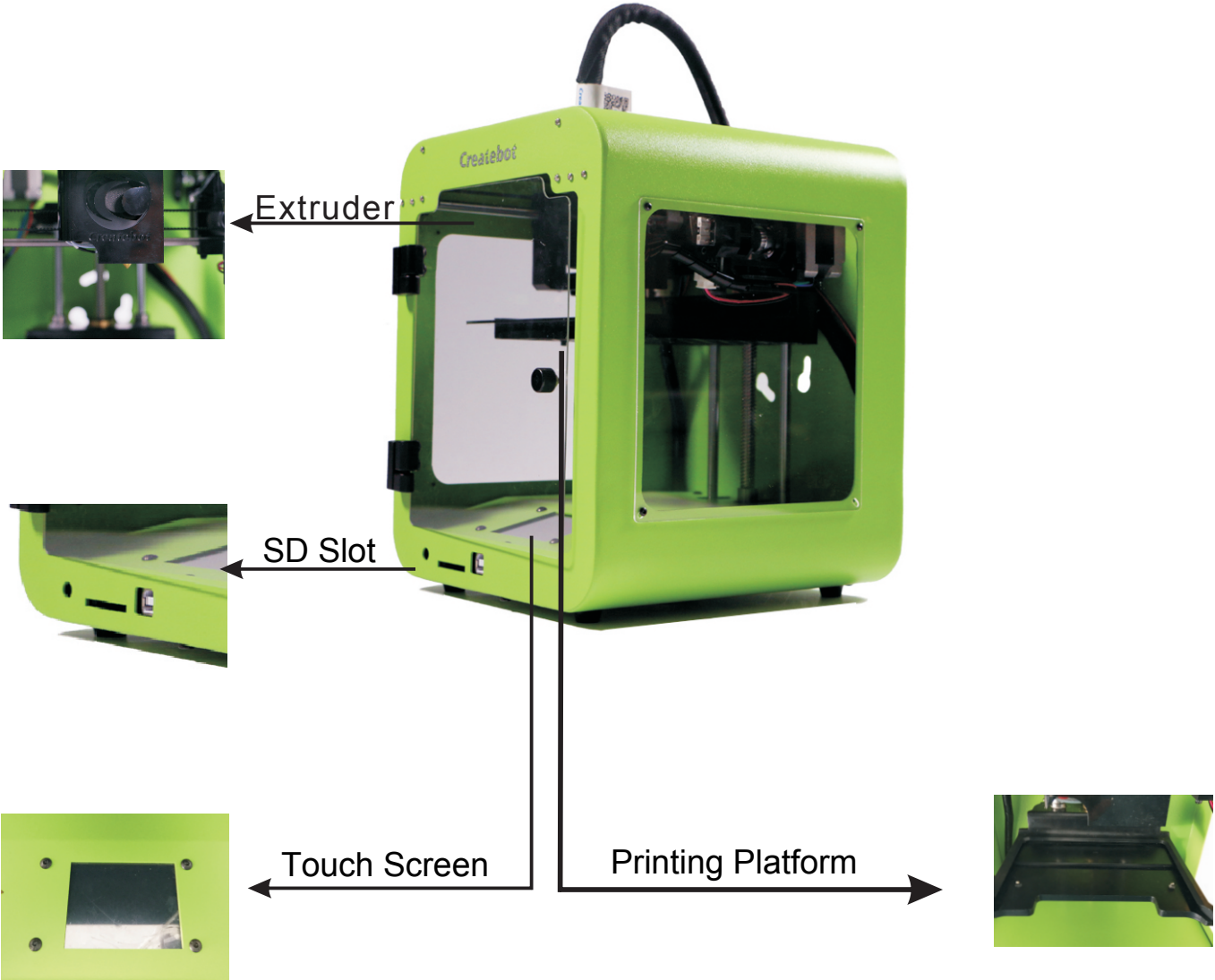

Operartion Guide

Step1

Taking out the three door plate,fix the left and right door plate on the printer with M4x6 screw.Then assemble the plastic parts and door handle with the M4x6 screw on front of the printer.

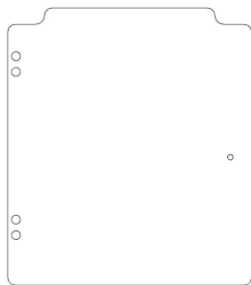

Door Plate x3



Assembled

Place the filament on the filament support

First,assemble the two filament support and put into the input slot on the back of the printer.Second,insert the filament into the white pipe till it reached the end which means the filament is on the extruder and ready to print.

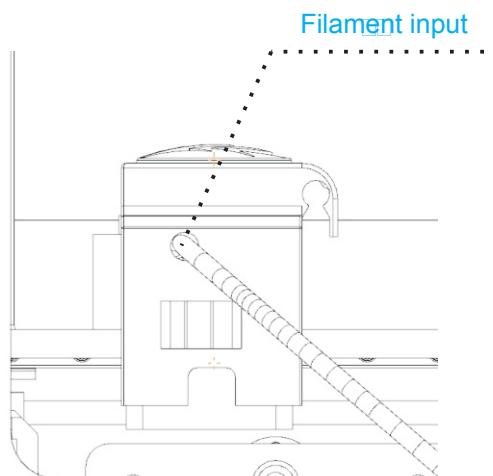
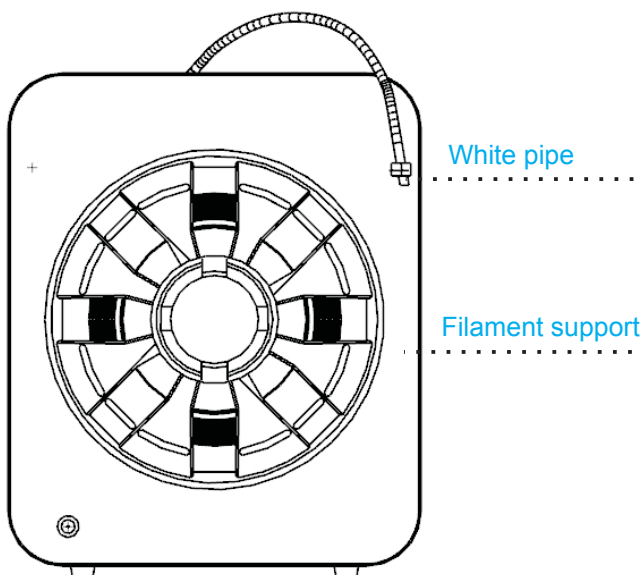

Step2

Turn on the Printer

Insert the power cable into the power input on the back of the machine and insert the power cable into the wall power connector. Then the printer will automatically running and you can hear the “di” sound. The display shows the startup interface, indicating that the 3D printer is running good.

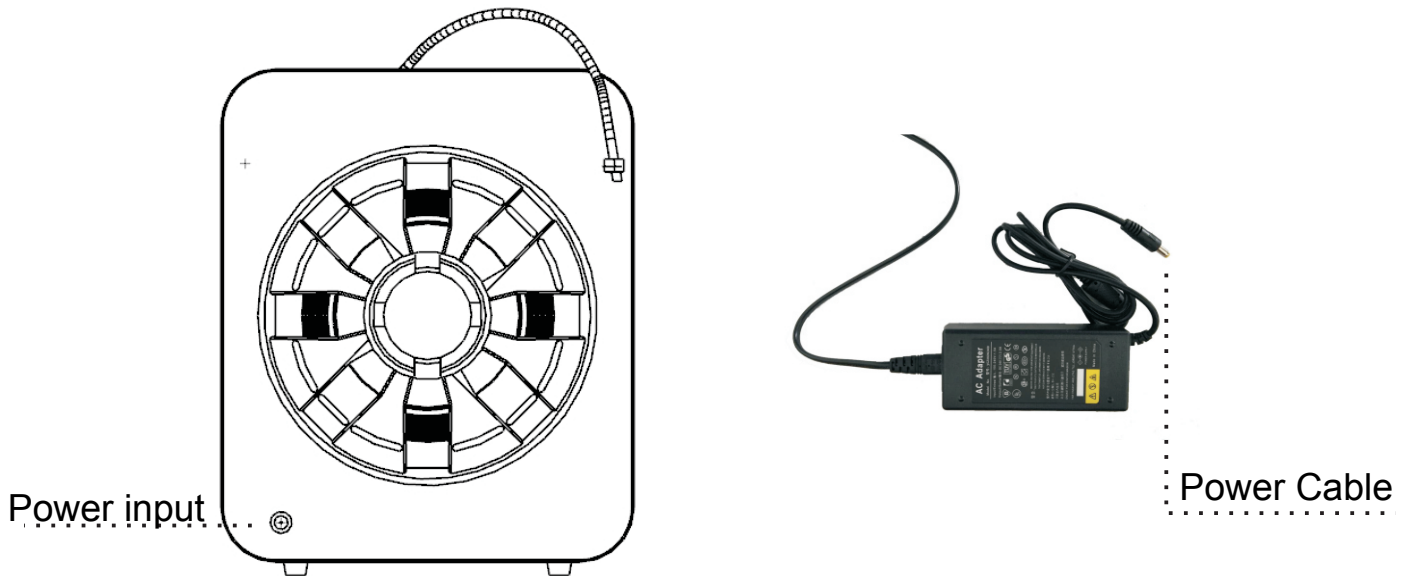

Firstly,press the tool button into the tool menu then press the PREHEAT button you can see the interface on picture 3 .Press the left up button to raise the temperature till it reached at 195-225C .

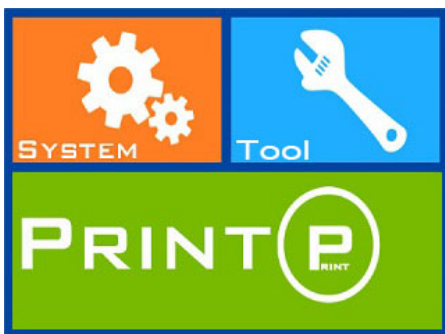

Home page

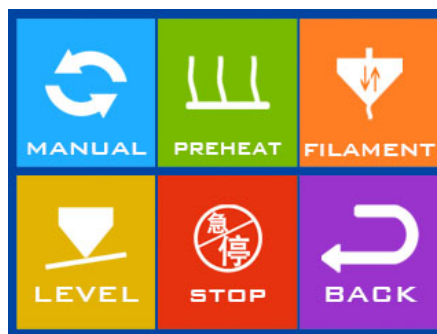

Tool menu

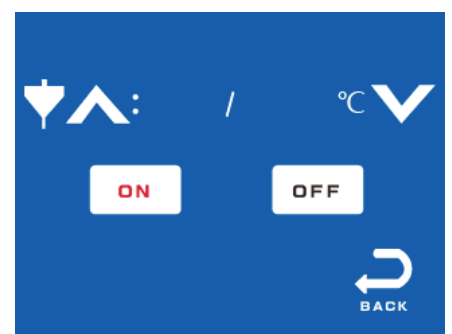

Preheat interface

Step3

Extruding Test

Click “TOOL”, then choose “FILAMENT” and click “DOWN” to extrude the filament. If it is extruded normally and smoothly, click “STOP” to finish it and click “BACK” to return to home page.



Tool Menu

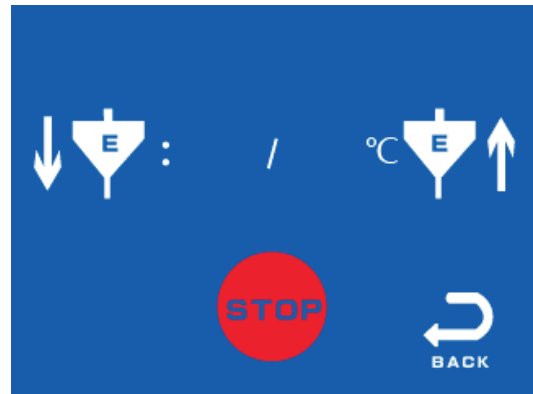

Load and unload the filament

Step4

Place the printing platform

First, put the magnet plate on the top of the printing platform. Then adjust the leveling screw to modify the gap between the extruder and the platform

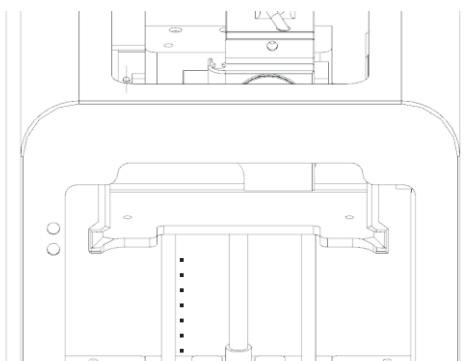

Printing Platform...



Printing Platform



Soft Magnet Plate

Gap adjusting screw



Step5

Printing Test

In the print home page, click the print icon, enter the print interface, open (openSD) icon, open the SD card file interface, choose the 001 testing model ,then the printer will start printing.



Home Page

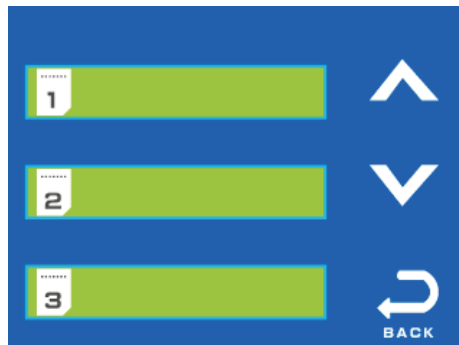

File select

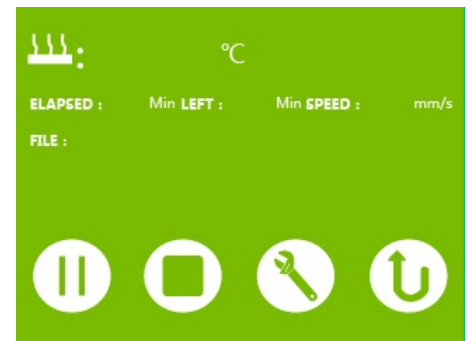

Printing interface

Slicing Software Installation

Copy the slicing software file from the SD card into your computer and Open the installer



Createbot 3D Software

Slicing Software



The software will install the drive automatically, click next to finish the installation

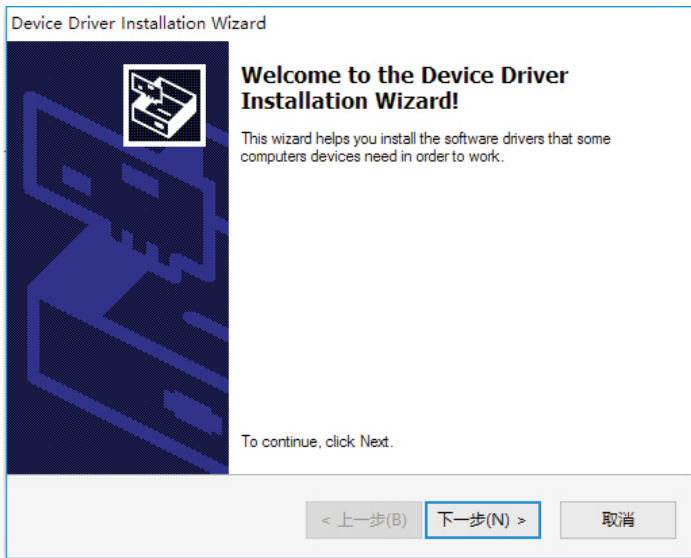

Select the path where the slice software is installed, then click Next, click Install, the software will automatically installed until finished

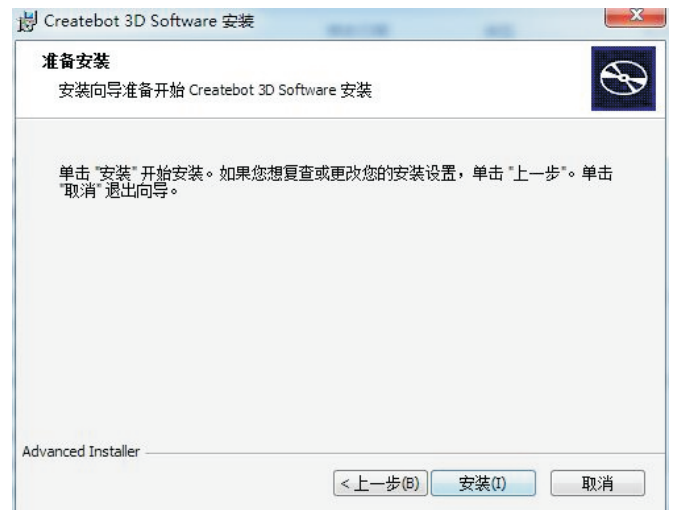
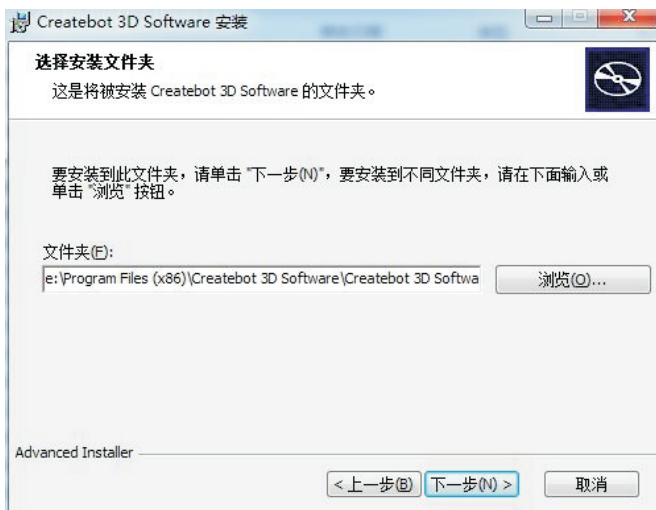

After the software is installed automatically, pop up the installation complete interface, click the Finish button, end the slice software installation.



First run the slice parameter configuration

Open the software and choose the English version, choosing the Super Mini, click the Next to finish



Recommended according to the following parameters, you also can adjust the by your own settings

The image shows a screenshot of a 3D printing software settings window. The window has a title bar with 'File', 'Tools', 'Machine', 'Export', and 'Help' menus. Below the title bar are four tabs: 'Basic', 'Advanced', 'Plugins', and 'Start/End-GCode'. The 'Advanced' tab is selected. The settings are organized into several sections:

- Quality**
 - Layer height (mm): 0.15
 - Shell thickness (mm): 0.8
 - Enable retraction: (with a menu icon)
- Fill**
 - Bottom/Top thickness (mm): 0.6
 - Fill Density (%): 65 (with a menu icon)
- Speed and Temperature**
 - Print speed (mm/s): 30
 - Printing temperature (C): 225
- Support**
 - Support type: Everywhere (with a menu icon)
 - Platform adhesion type: Raft (with a menu icon)
- Filament**
 - Diameter (mm): 1.75
 - Flow (%): 100.0

Note:

When selecting a support type, it is possible to determine whether it is necessary to add partial support or entire support or without support by observing the model or slice interface. But in principle it is better to avoid support or reduce support. Rotate model can be used to avoid or reduce the purpose.

When selecting the type of platform attachment, the edge or grid can be appropriately added according to the size of the land area and the height of the model.

File	Tools	Machine	Expert	Help
Basic	Advanced	Plugins	Start/End-GCode	

Machine

Nozzle size (mm)

Retraction

Speed (mm/s)

Distance (mm)

Quality

Initial layer thickness (mm)

Initial layer line width (%)

Cut off object bottom (mm)

Dual extrusion overlap (mm)

Speed

Travel speed (mm/s)

Bottom layer speed (mm/s)

Infill speed (mm/s)

Top/bottom speed (mm/s)

Outer shell speed (mm/s)

Inner shell speed (mm/s)

Cool

Minimal layer time (sec)

Enable cooling fan

Adjusting the model

1 Click the red box on the picture below



2 Choose the STL file

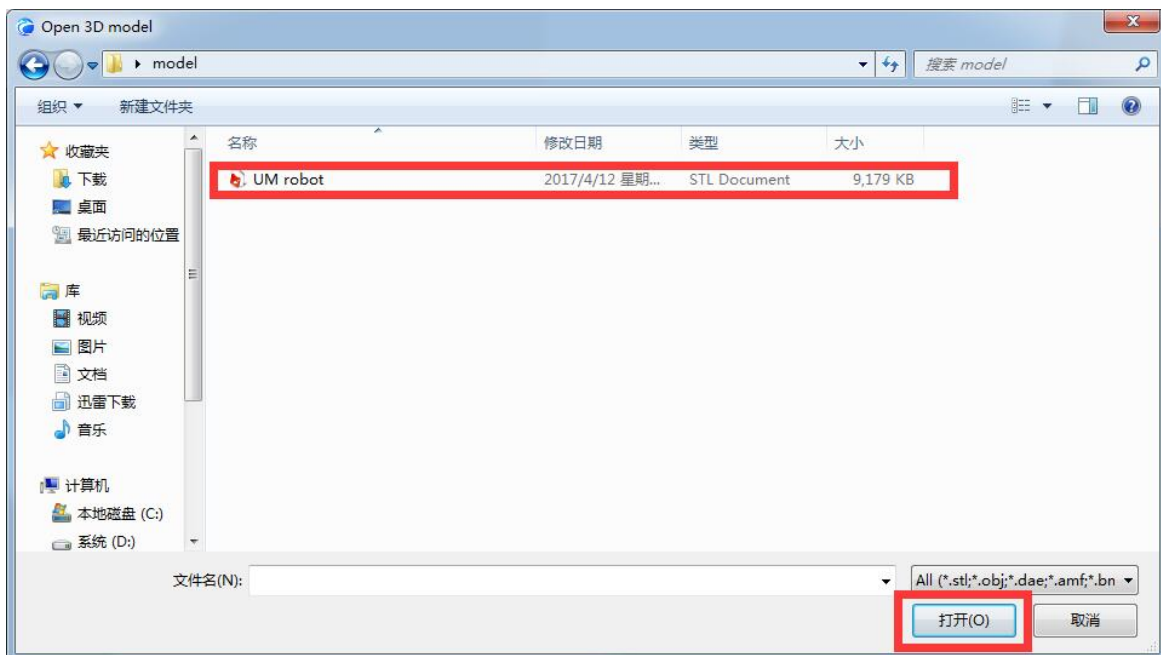

3 click the model you will see the picture like below

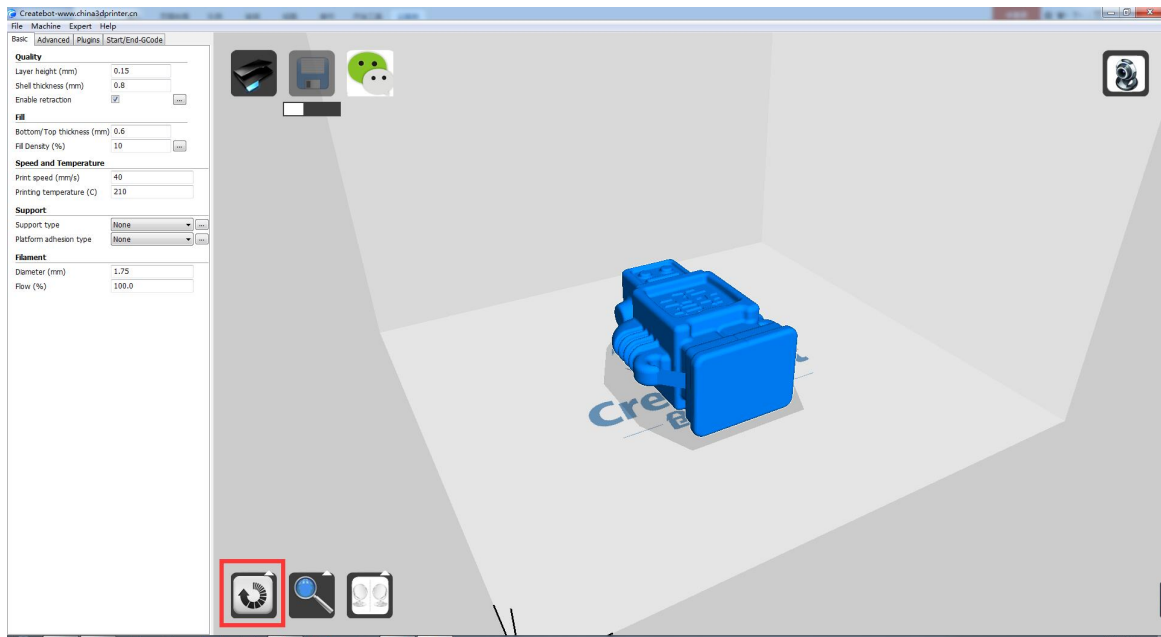

4 click the rotate button to adjust the model

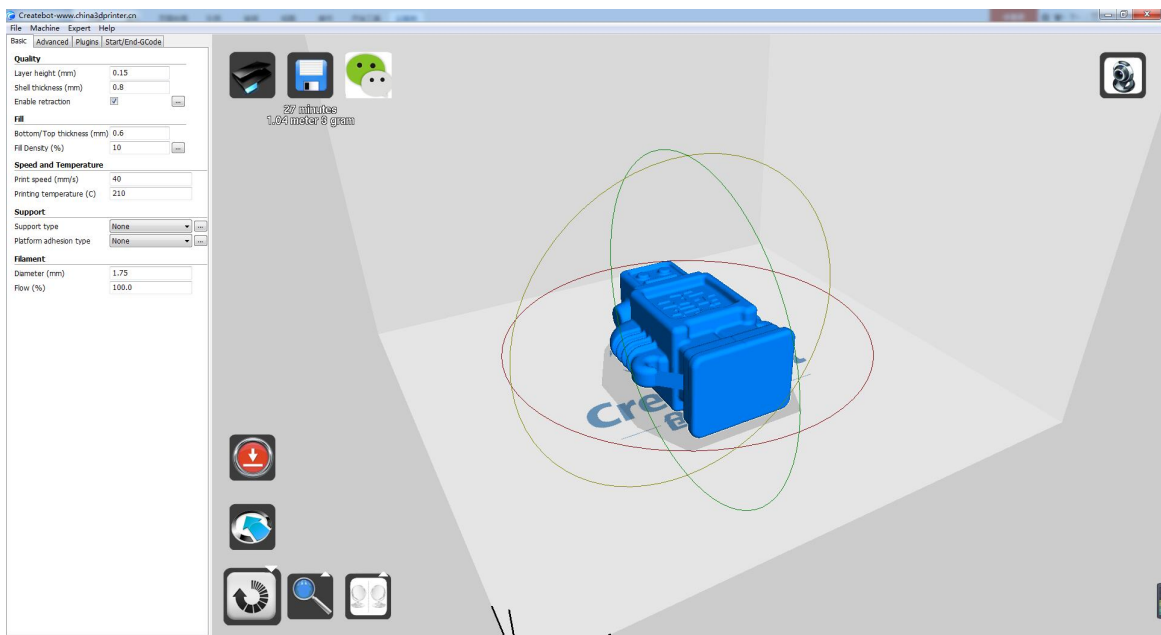

5 Export the model in Gcode by click the button like picture below

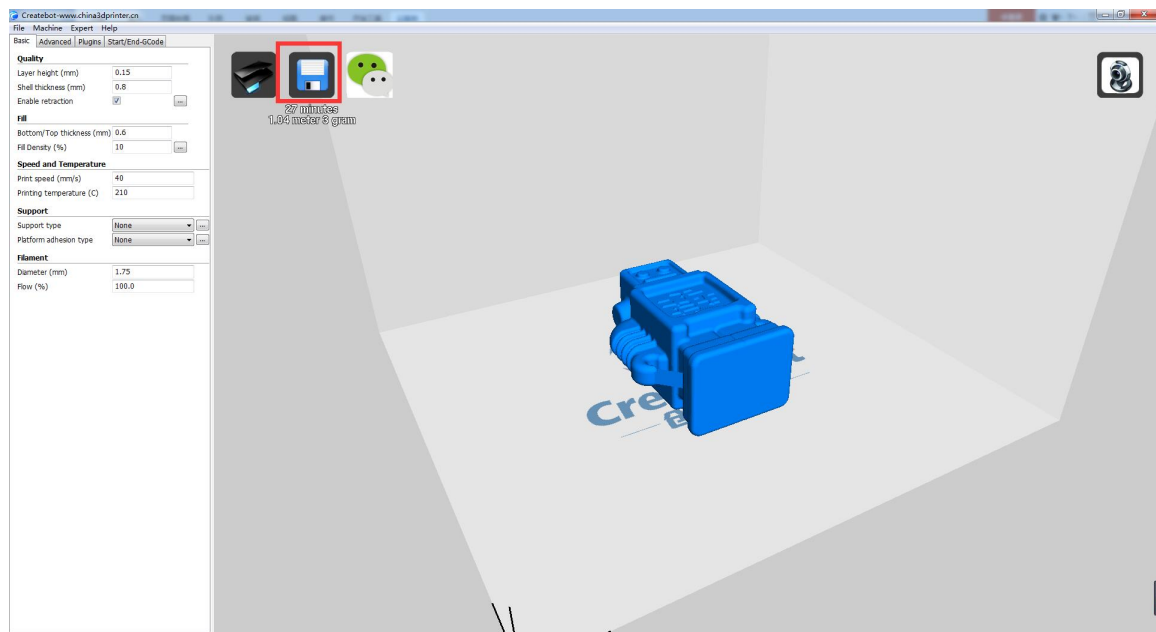

6 Save the Gcode to the SD card and insert into the printer

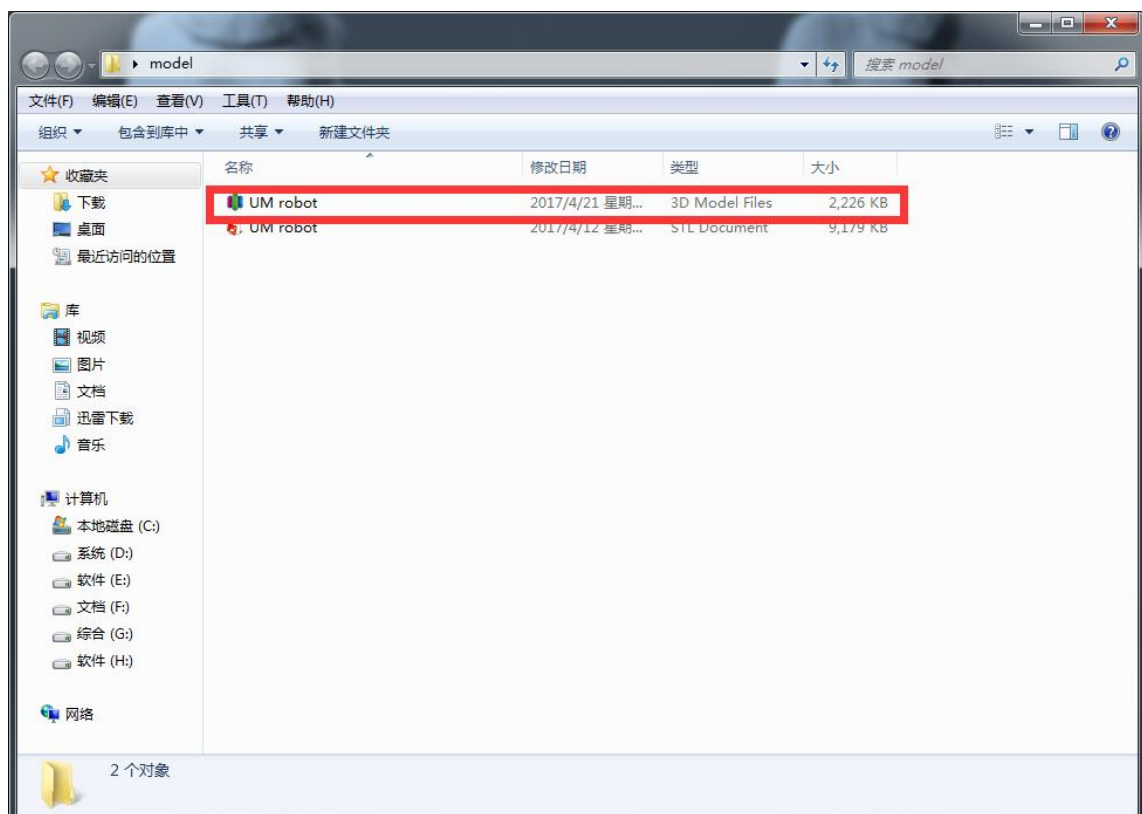



Thanks for your support

**Any questions please feel free to contact us
More details welcome to visit our official website**



0086-574-88037579

www.createbot.net

www.facebook.com/createbot.net/